



# FIXING SYSTEMS FOR PHOTOVOLTAIC MODULES

# POLISH MANUFACTURER OF PHOTOVOLTAIC STRUCTURES

## AWARDS



**5 GW+** PRODUCED PV STRUCTURES

**160+** employees

**2015** year of foundation

**45+** registered designs at the EU office

**7** automated production lines

**2** production establishments in central Poland

**Who are we?**  
Durability and safety. The highest quality of products. A unique offer of personalized mountings for photovoltaic modules. These are the key values on which the operations of Energy5 are based. Being a leading producer and designer of photovoltaic structures, we apply a strategy based on providing products of the highest quality, along with innovative and tested solutions. We are a pioneer of research on photovoltaic structures – in particular related to their corrosivity. We rely on experience, our staff consists of qualified engineers, operators and specialists.

- Offer**
-  **PRODUCTION AND DELIVERY** of photovoltaic structures
  -  **INDIVIDUAL DESIGN** assembly systems
  -  **TECHNICAL AND SERVICE SUPPORT**
  -  **FREE PRODUCT TRAINING**



# Modern MACHINE POOL



**2 PRODUCTION ESTABLISHMENTS**  
in central Poland



**7 AUTOMATED LINES,**  
originating from leading manufacturers



**3200 M<sup>2</sup>**  
of manufacturing areas



**SIZE CUSTOMIZED**  
manufacturing

### ► Comprehensive studies

To ensure the required safety in use, we create ready to use fixing systems for photovoltaic modules, testing all connecting elements in the set. The conducted tests confirm the declared level of performance characteristics, required by law for construction products of this type.



### ► The highest standard

With our experience, innovative technology and cooperation with leading research and scientific centres, our products meet the highest standards, while they maintain certificates, standards and approvals required by the Polish law.





# Tests AND CERTIFICATES

## Products certified by the NATIONAL TECHNICAL ASSESSMENT

The document authorizes to use in trading and in the construction industry on the domestic market.



### National Technical Assessment

The range of functional and operational features of the Energy5 structure is much wider than that required by the range of the EN-1090-1 standard.



### Factory production control

All products undergo internal control of the production process in order to monitor its quality level.



### Certification of Factory Production Control

Energy5's products have certificates of conformity awarded to the Factory Production Control pursuant to the EN 1090-1,2,3 standard

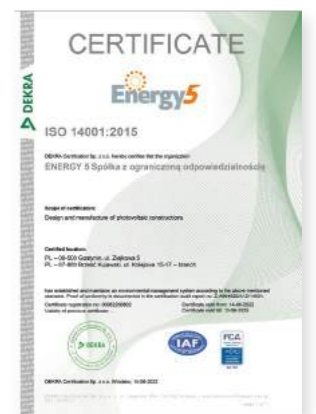

### Environmental Management System

in compliance with ISO 14001:2015 standard



### Security Certificate. Controlled production

Energy5 products have a certificate issued by TÜV Rheinland, an independent entity, internationally recognized. It does confirm the highest quality and safety of products.

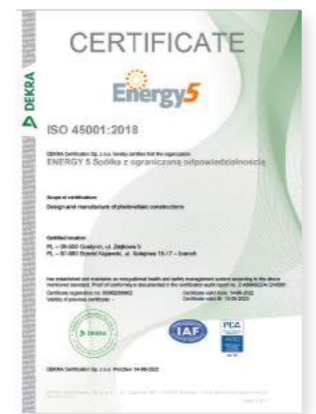

### Occupational Health and Safety System

in compliance with ISO 45001:2018 standard

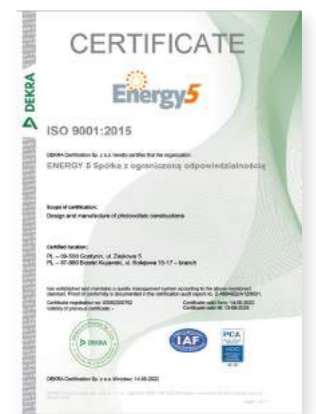

### Quality Management Systems

in compliance with ISO 9001:2015 standard

The technical features of the Energy5 structure are confirmed by TYPE tests carried out at the Building Research Institute in the scope of:

- Product classification in terms of their shape and dimensions, for conformance with PN-EN 755-9:2010.
- Classification of aluminium profiles according to their durability, in accordance with PN-EN 1999-1-1:2011.
- Classification of steel sections in the environment of the corrosion class up to C5 pursuant to PN-EN ISO 12944-2: 2018 standard.
- Connections strength.
- PV panels loading, including their supporting structure.
- System strength on a flat roof in the aerodynamic tunnel.
- Strength of the Aero S and Aero EW systems glued or welded to be covered with a membrane in the aerodynamic tunnel.



Additional Energy5 tests, crucial for the safety and durability of the photovoltaic system:

- Shear and tensile strength of connections - inter alia related to hammer screws setting in the channels of aluminum or steel profiles.
- Resistance of PV panels together with the structure in terms of the load of wind and snow impact.
- Forces transmitted by middle and end mounting clamps.
- Resistance of the set to an impact of a soft - heavy or hard - light body.
- Durability of the whole set, depending on the corrosive class of the environment.
- The weight of the sets, which is very important when testing roof load.

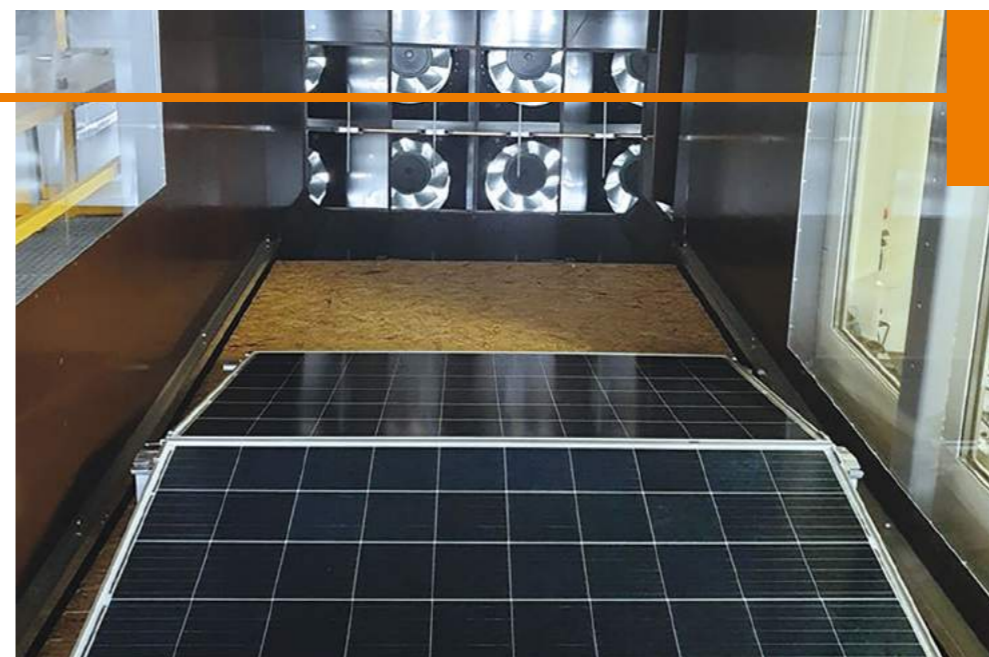



# Freestanding SYSTEMS



## ▷ What the freestanding systems are?

The freestanding systems are overground structures, enabling installation of over a dozen PV modules in household installations, up to hundreds of thousands modules at huge photovoltaic power plants, generating impressive amounts of energy.

## ▷ Individual approach

The systems proposed by us are selected individually, taking into account the **shape of a terrain, geotechnical conditions, and wind and snow zones in a specific location**. We manufacture structures for modules with an aluminium frame, as well as for glass-glass or bifacial modules. We provide a support of well-qualified specialists from a design to a final installation.



a guarantee for the systems for up to 25 years



different table inclines



vertical or horizontal layout of the modules



structures adopted to glass-glass and bifacial modules

## ▷ Extensive range

We offer pile driving services, including **pull out tests for structural piles**, required for a correct installation of the structure.

## ▷ Safety guarantee

We make all efforts possible to ensure that systems designed by us not only **reduce monthly electricity bills, but are also safe**. We perform tests of all connecting elements in the system, guaranteeing **the long-term reliability and smooth operation**.

## ▷ Resistance to corrosion

To ensure correct protection against corrosion, the overground Energy5 systems are made of black steel, S320, coated with the metallic coat Magnelis®. The coating is characterised by its significantly **higher resistance to corrosion**, when compared to galvanised products. This innovative coating guarantees a long-term protection against corrosion in aggressive environmental conditions, up to the corrosion class C5, and this translates into the increased life of the photovoltaic systems.





# Freestanding SYSTEMS



## Photovoltaic tracker TR/V1/R or TR/V1/K

The Energy5 photovoltaic tracker is a single axis system that follows the sun. It allows modules to be mounted in a single row up to a maximum length of 98 m.

- It stands out with yields up to 30% higher than still PV structures. Exceptional efficiency of the solar system is ensured by the sun-tracking feature, which aligns the PV modules optimally to the direction of sunrays.
- The system is controlled through an astronomical clock, while the system security is provided by smart sensors that measures wind strength and direction. When the critical values are exceeded, the system automatically forces the panels into the safe position.

- The Energy5 tracking system is also equipped with snowfall sensors. When heavy precipitation is detected, the trackers go into automatic snow removal mode and angle the structures to allow snow to slide off or the structures to be cleaned.

### PHOTOVOLTAIC TRACKER SYSTEM SPECIFICATION:

Material	black steel with Magnelis® coating or galvanized steel
Number of module rows	1
Layout	vertical
Incline	+/- 60°
Maximum tilt of the tracker in the north-south direction	4°
Fixing method	driven in / concrete
Guarantee	up to 25 years guarantee for perforation
Adapted to bifacial modules	yes
Minimum module-to-ground clearance	400 mm

### BACKTRACKING FUNCTION – ROW SHADING MINIMIZATION

The 3D-backtracking algorithm calculates the angle of the panels to prevent shading of the consecutive rows of modules. This function allows the panels to be rotated to a position in which the shadow cast is shorter and bypasses the next row, ensuring the highest efficiency of the follow-up system.

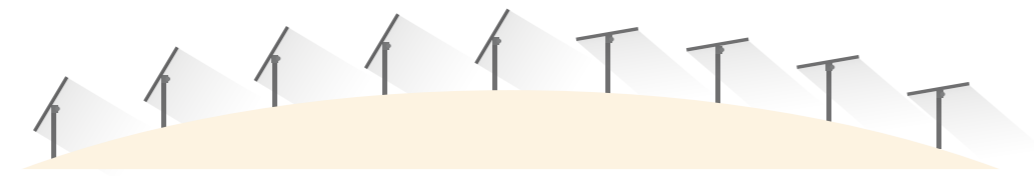

SUN TRACKING system



3D BACKTRACKING minimize row shading



SNOW REMOVAL



EMERGENCY POWER system



additional feature: 24/7 MONITORING APPLICATION



# Freestanding SYSTEMS

TABLES DRIVEN IN OR FIXED MECHANICALLY

## BIFACIAL - WITH TWO SUPPORTS

▷ Horizontal arrangement of four modules

▷ **The bifacial system** is characterised by a reduced shadowing of modules by structural elements. The structure profiles are spaced in such way that they enable a maximum exposure of the bottom side of the bifacial modules to reflected and scattered light.

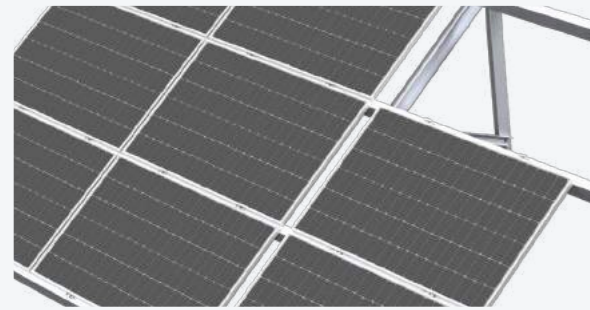

# Freestanding SYSTEMS



## BIFACIAL - WITH TWO SUPPORTS

▷ Vertical arrangement of two modules.







# Freestanding SYSTEMS

## DRIVEN IN – WITH TWO SUPPORTS

▶ Horizontal arrangement of four modules.

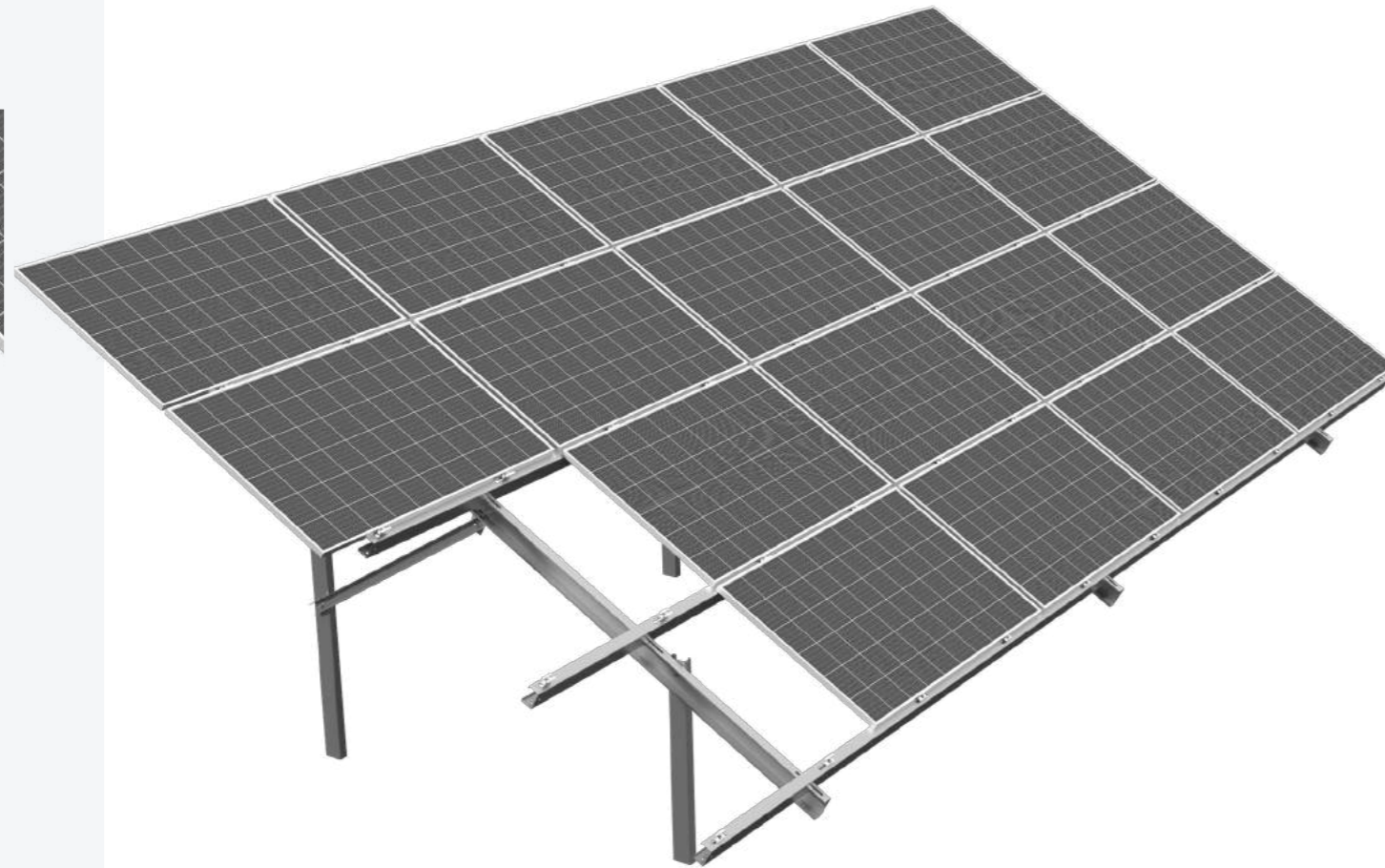
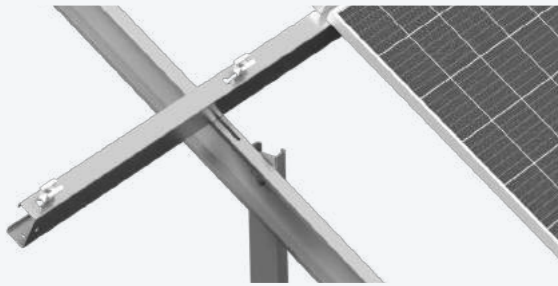

# Freestanding SYSTEMS



## DRIVEN IN - WITH TWO SUPPORTS

▶ Vertical arrangement of two modules.

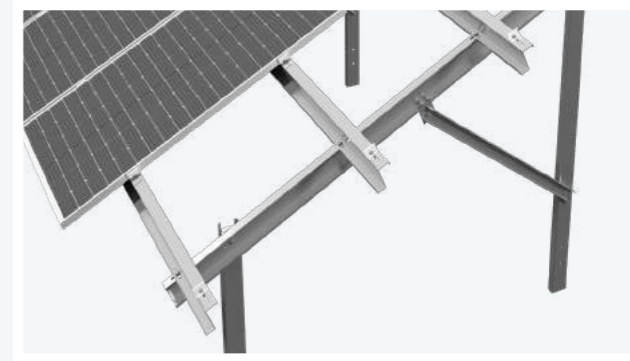



# Freestanding SYSTEMS

## DRIVEN IN - WITH THREE SUPPORTS EAST / WEST

▶ Horizontal arrangement of four modules.



# Freestanding SYSTEMS



## MECHANICALLY FIXED - WITH TWO SUPPORTS

- ▶ Horizontal arrangement of four modules.
- ▶ Option for a different configuration of the modules.





## Roof SYSTEMS



FOR FLAT ROOF



FOR PITCHED ROOF

### ► What are the roof systems?

Roof systems are solutions in which a **roof is used as a surface for fixing of photovoltaic modules**. The installation method is selected according to the **roof structure** and **decking**.

**When selecting the roof fixing system, the following aspects are particularly important:**

- roof load bearing capacity, i.e., its acceptable load,
- roof tightness, being a precondition for the use of an invasive system.

### ► Extensive range

The systems offered for flat roofs (the incline of up to 5°) include Ekierki Eco, with a ballast or fixed mechanically, as well as ballast aerodynamic systems Aero S and Aero EW.

We also offer systems for pitched roofs (the incline exceeding 5°), selected individually for each type of roof decking. With a small number of elements, the roof systems are quick and easy to assembly.

### ► Resistance to corrosion

Roof structures are made of **high quality aluminium profiles**, with all connecting elements manufactured of **stainless steel**. This type of connection is the best solution for structures exposed to adverse weather conditions, ensuring an **excellent resistance to corrosion**.



**a 10-year guarantee**  
for the systems



**vertical or horizontal**  
layout of the modules



structures adopted to  
**glass-glass modules**



AERO S - INCREASED HEIGHT SOUTH

AERO EW - INCREASED HEIGHT EAST/WEST

Aerodynamic systems on a support of the increased height allow to maintain 10-centimetre distance between the module frame and the roof surface. The systems include individually designed AERO profiles. Special connections in profile joints enable adjusting rotation to ensure precise adhering to the module surface. The systems of the increased height for a flat roof ensure better air circulation and protection of cables, thus guaranteeing that fire-prevention conditions of module manufactures are met.

Fixing method: glueing or heat sealing / weighing down with ballast

Possibility of mounting both on the short\* and long side of the module

\* Horizontal installation of large modules on their short side is only possible when a manufacturer of the modules allows it.

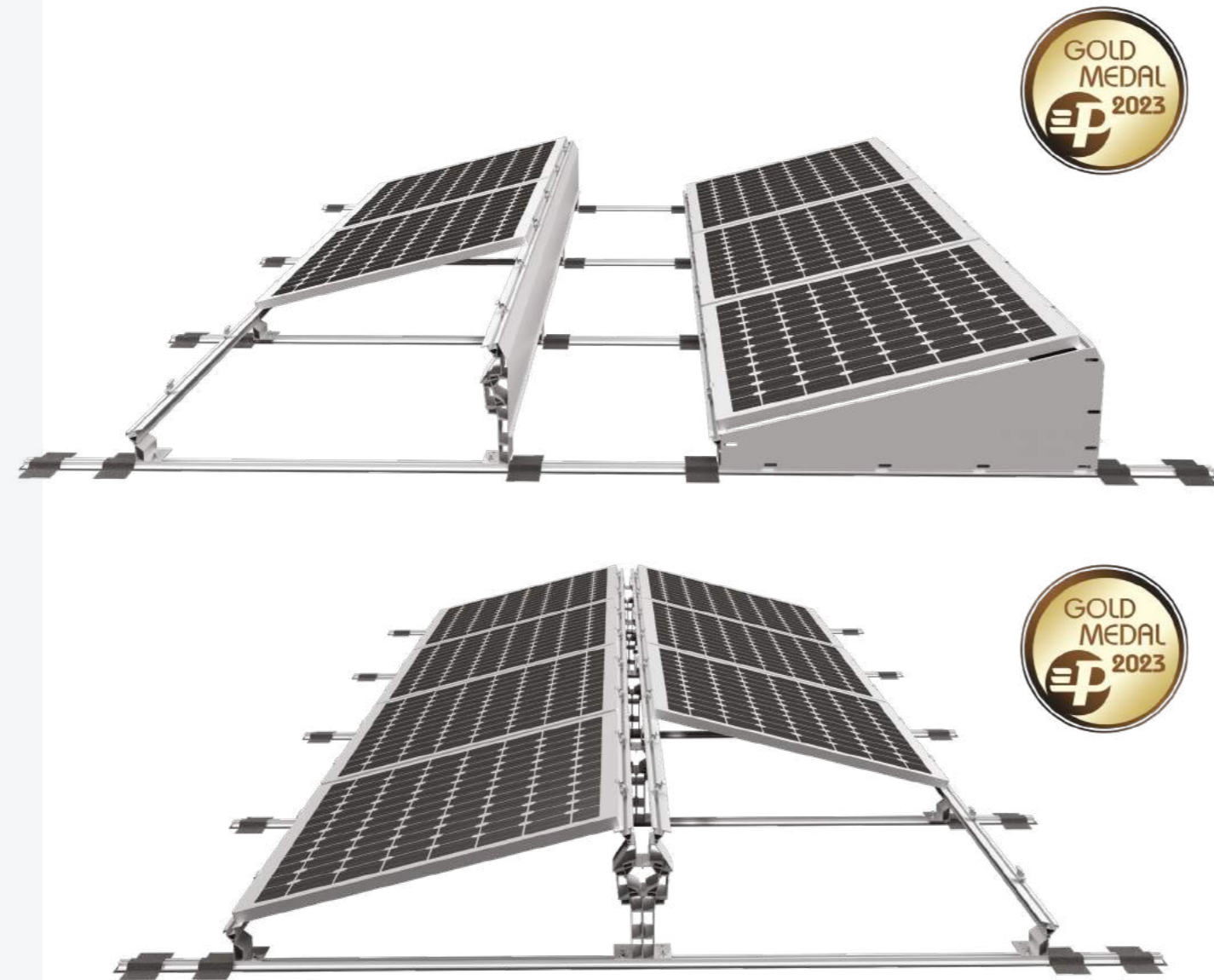

AERO S - GLUED\* SOUTH

AERO EW - GLUED\* EAST / WEST

The Aero S / EW system glued to membrane is based on glueing of fixing components from the same material as the roof decking. This way, a stable structure can be formed without unnecessary loading of the roof. The installation does not interfere with the roof decking.

Fixing method: glueing or heat sealing

Possibility of mounting both on the short\* and long side of the module

\* Horizontal installation of large modules on their short side is only possible when a manufacturer of the modules allows it.



AERO S\* SOUTH

▶ An advantage of the Aero S is a permanent connection of rows and the use of side and rear covers, which minimise the wind influence on the structure, help to reduce the amount of required ballast, and in consequence, decrease the roof load. The installation does not interfere with the roof decking.

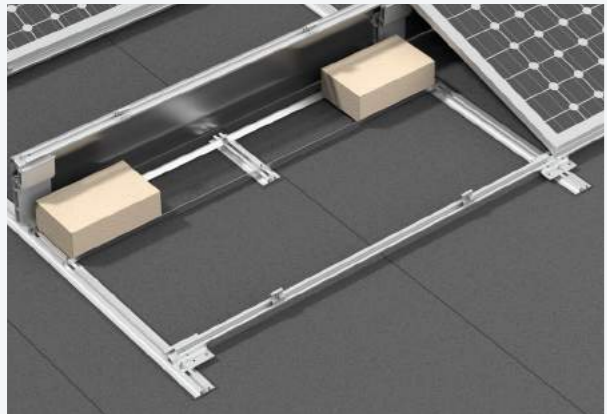
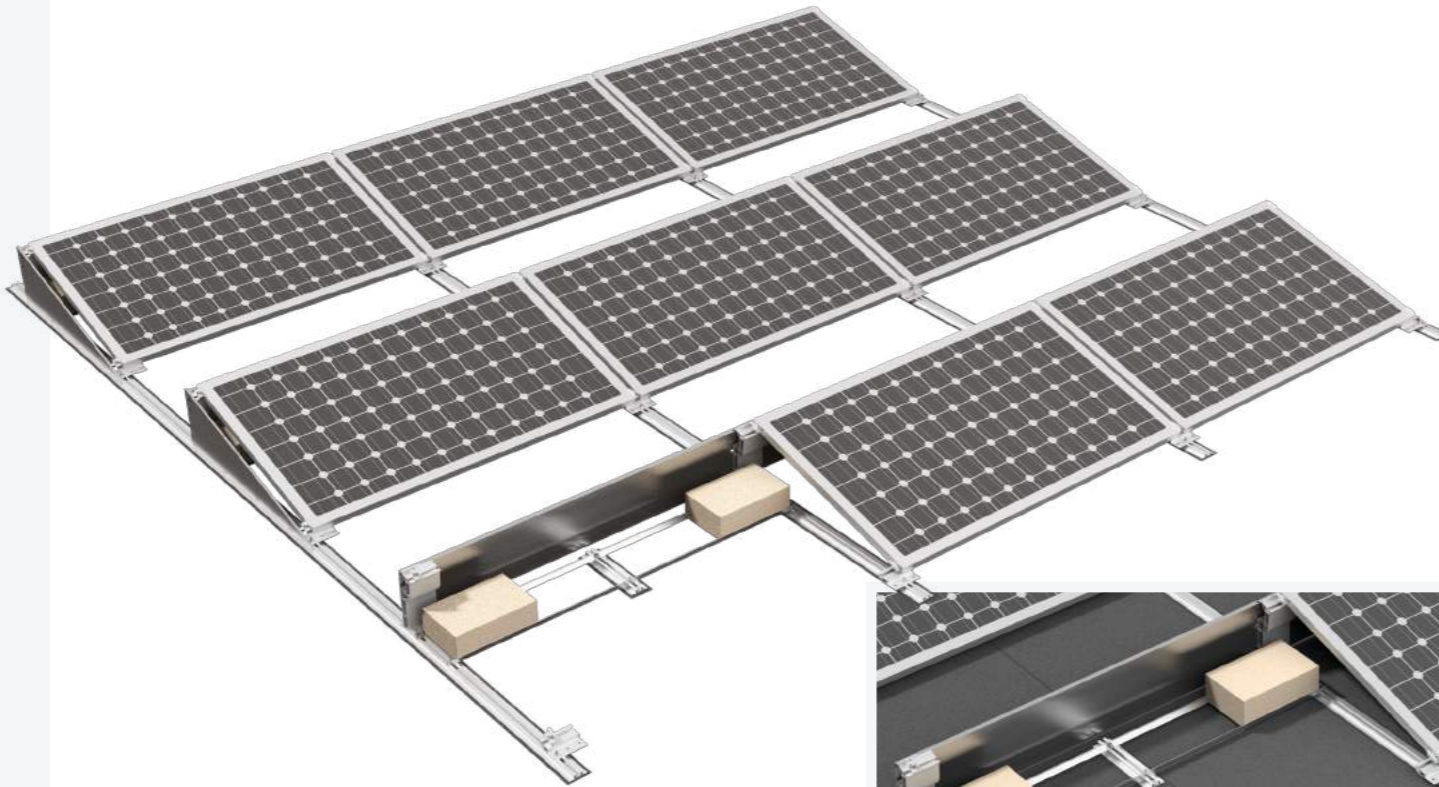

INSTALLATION ALONG A LONG SIDE

\* Horizontal installation of large modules on their short side is only possible when a manufacturer of the modules allows it.

AERO EW\* EAST / WEST

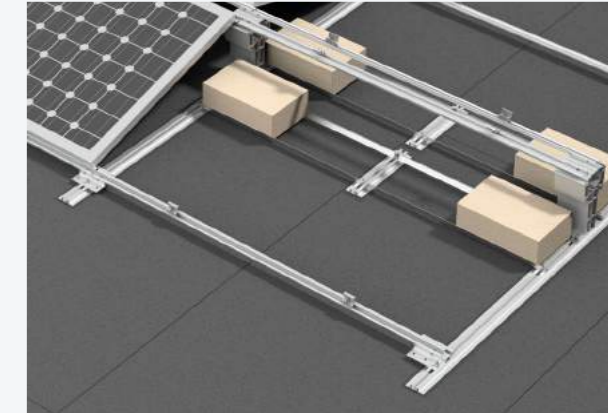
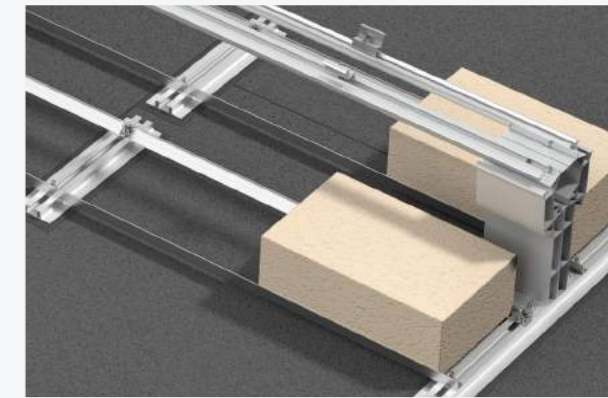
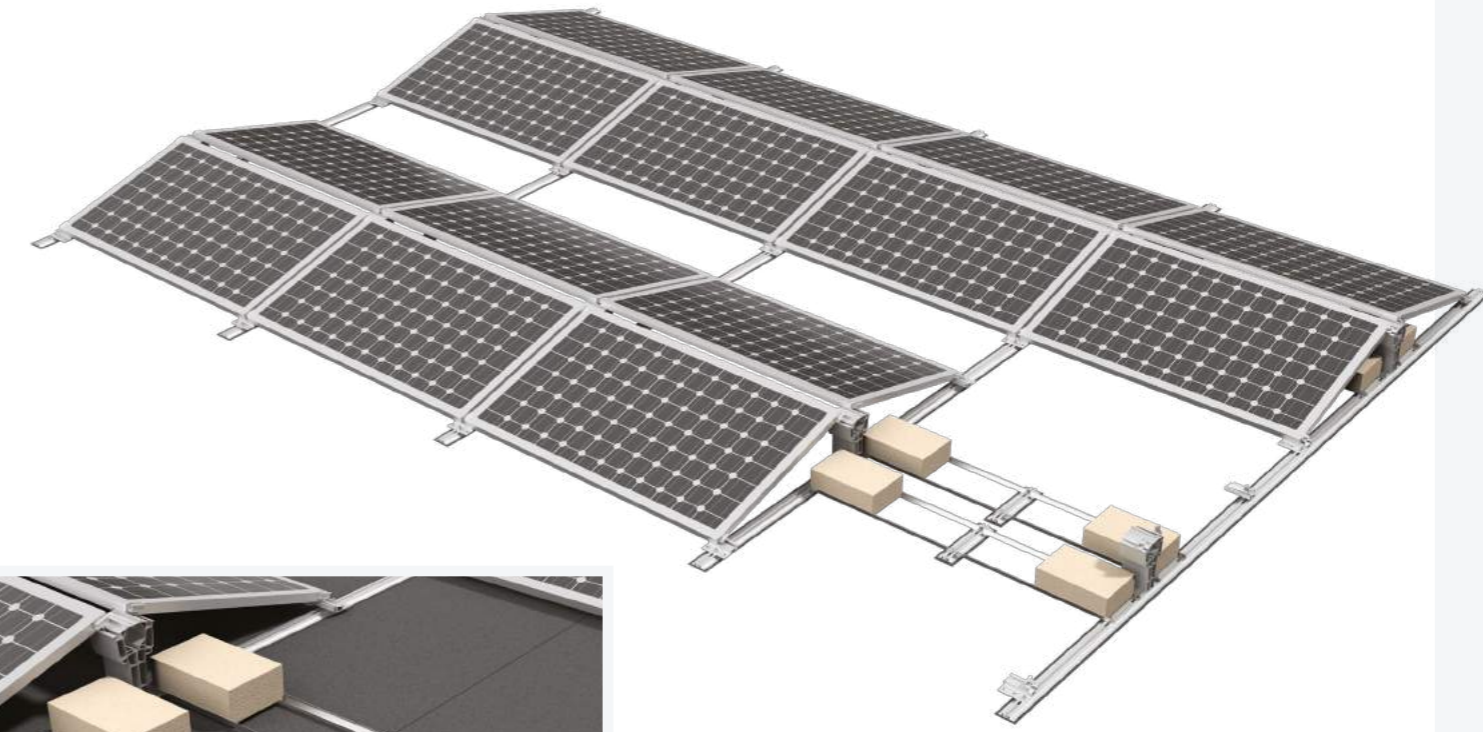

INSTALLATION ALONG A LONG SIDE

\* Horizontal installation of large modules on their short side is only possible when a manufacturer of the modules allows it.

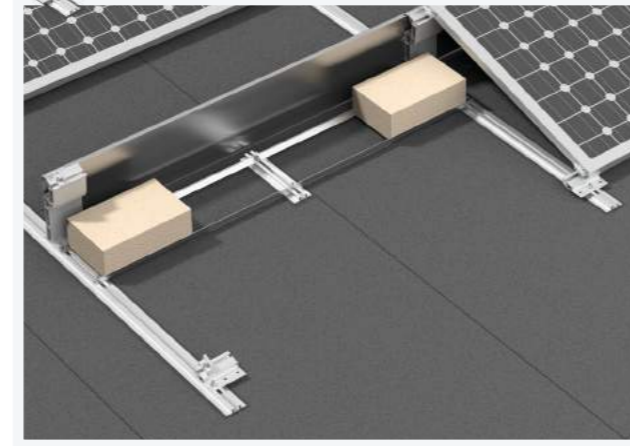

INSTALLATION ALONG A SHORT SIDE

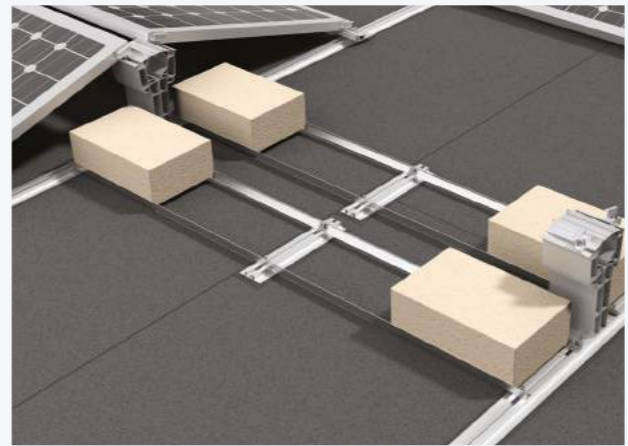

INSTALLATION ALONG A SHORT SIDE

# Systems FOR FLAT ROOFS

## EKIERKA ECO WITH THE BALLAST\*

▶ An advantage of the Ekierka Eco solution is a possibility to install modules horizontally, and to set the structure at different inclines. The installation does not interfere with the roof decking.

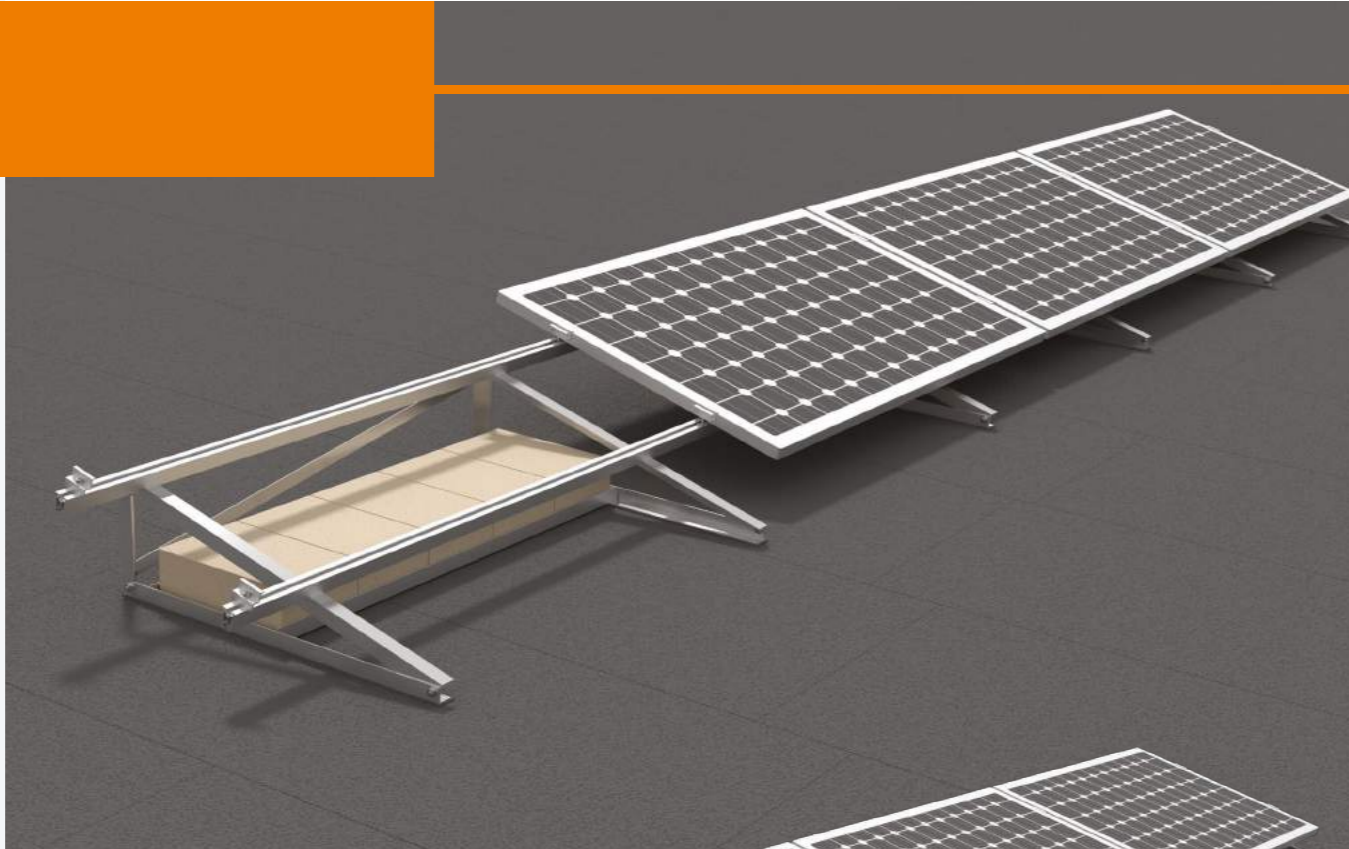

## EKIERKA ECO - MECHANICAL INSTALLATION\*

▶ An option of vertical or horizontal installation.

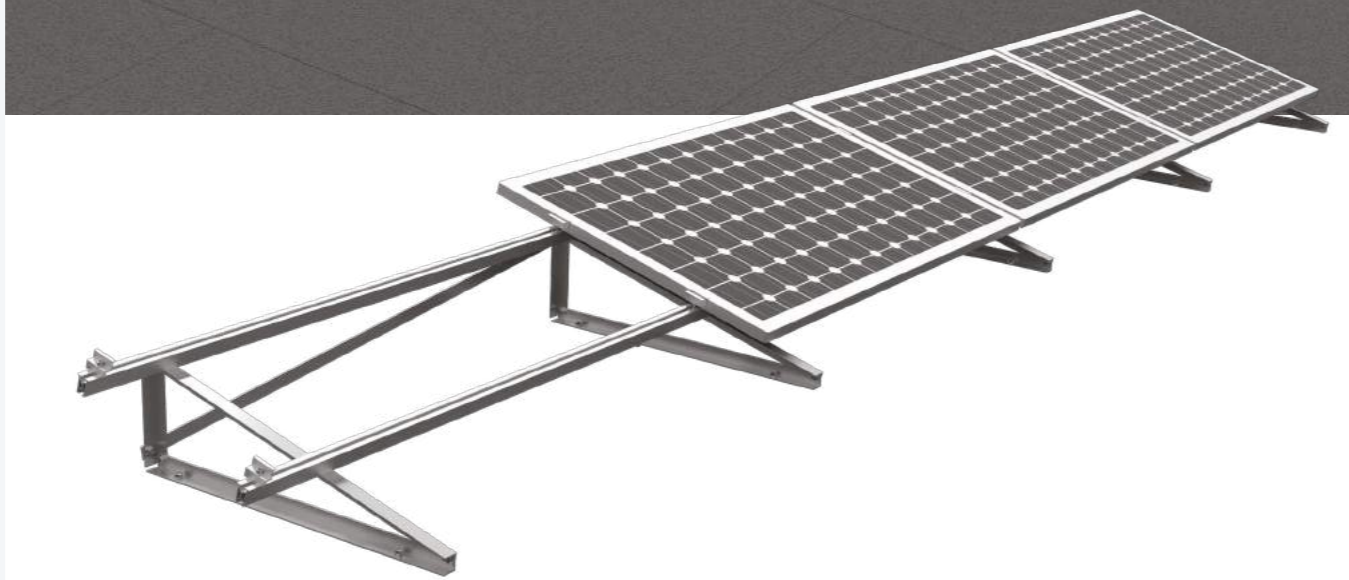

\* Horizontal installation of large modules on their short side is only possible when a manufacturer of the modules allows it.

# Systems FOR PITCHED ROOF

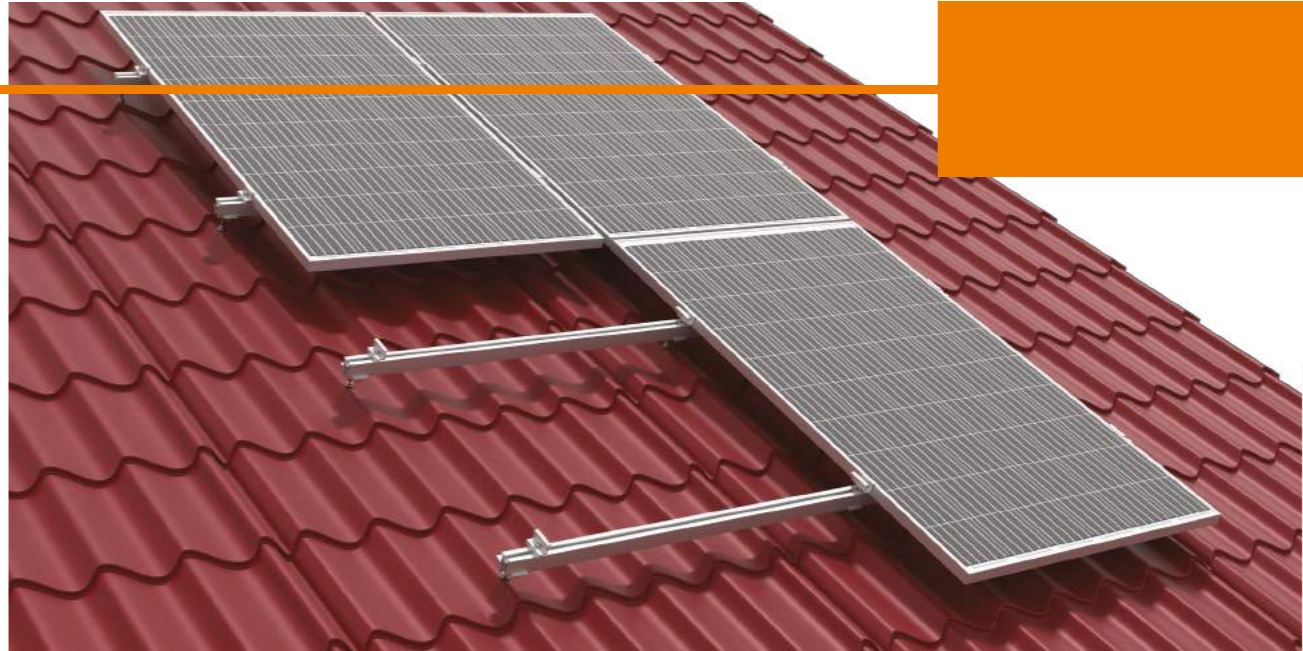

## COVERED WITH METAL ROOFING TILES

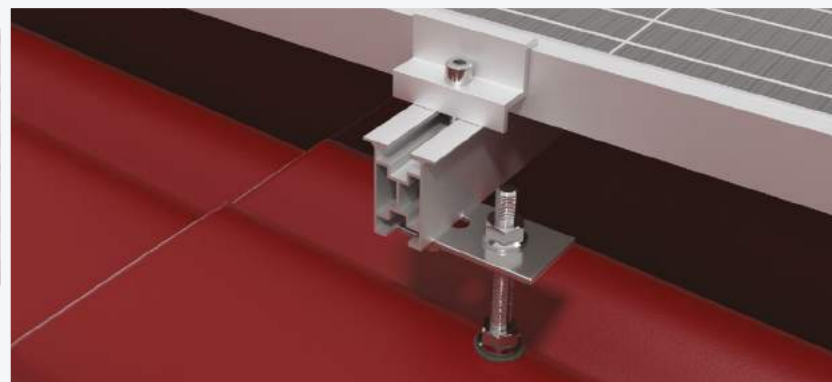

## COVERED WITH METAL ROOFING - CROSS SYSTEM

▶ Horizontal, cross installation with double threaded bolts.



Systems FOR PITCHED ROOF

COVERED WITH TRAPEZOID METAL SHEETS

Installation with a trapezoid bridge.

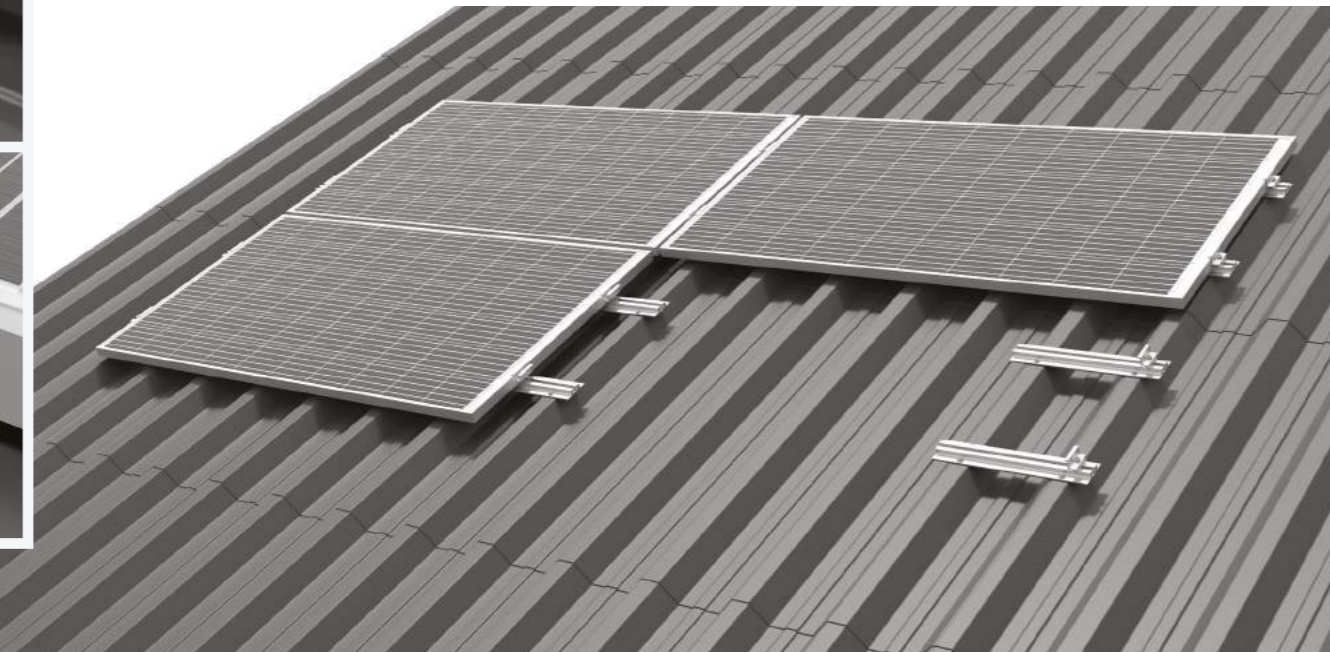
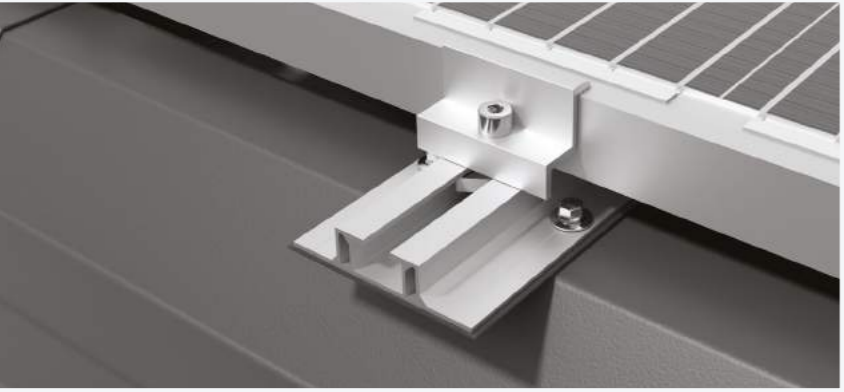
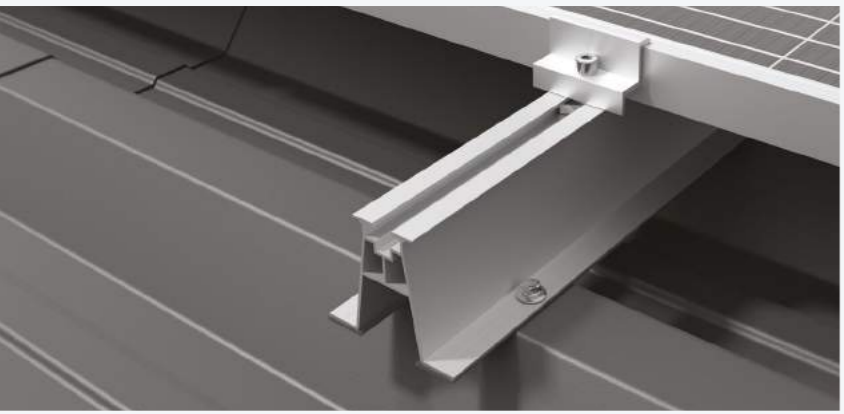
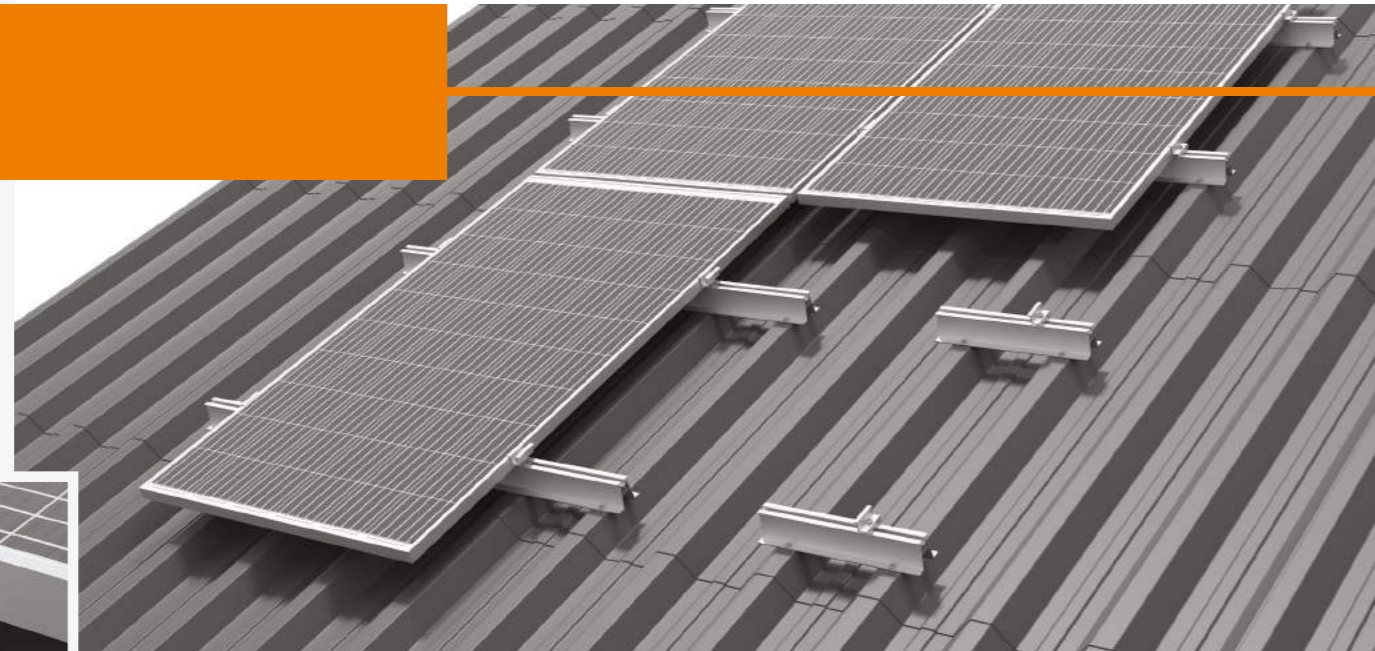

Systems FOR PITCHED ROOF

COVERED WITH TRAPEZOID METAL SHEETS

Installation with a long trapezoid rail.

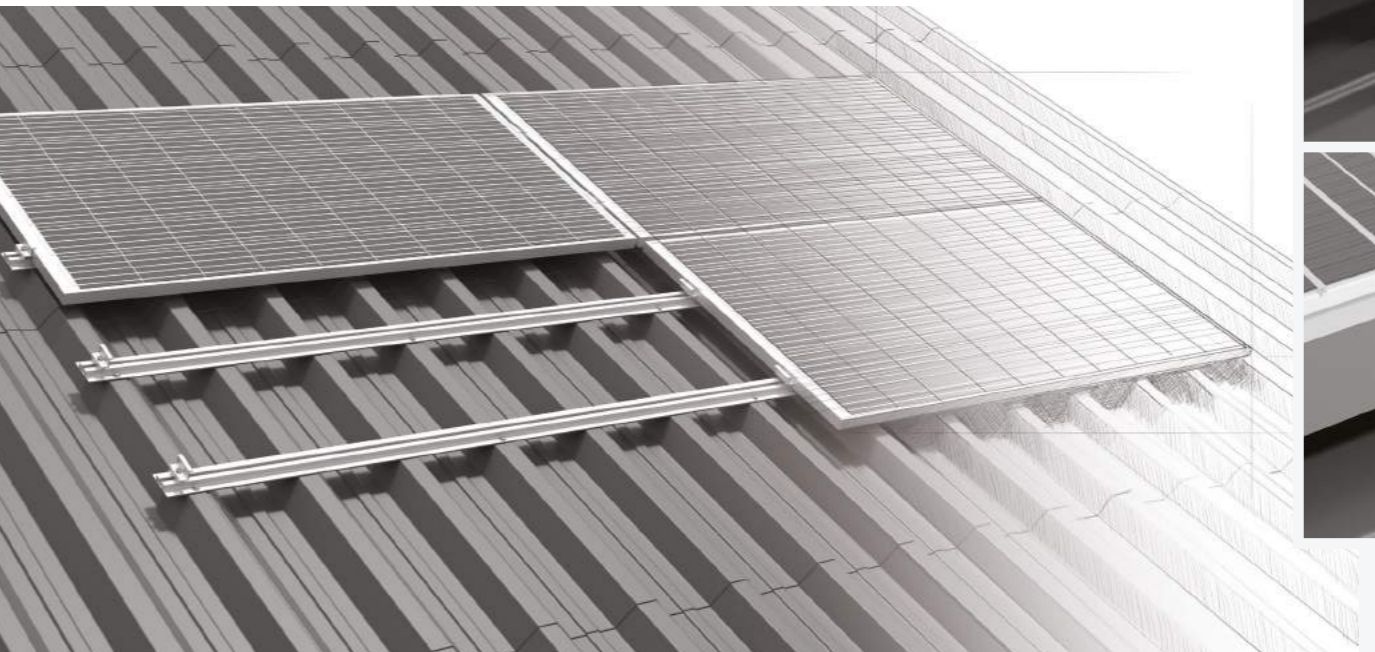
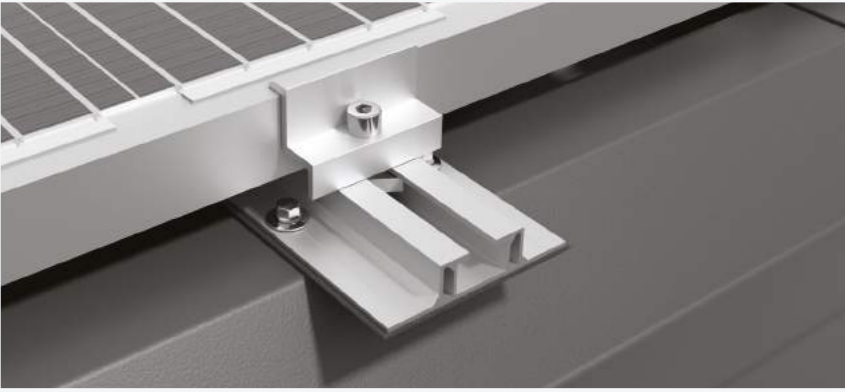
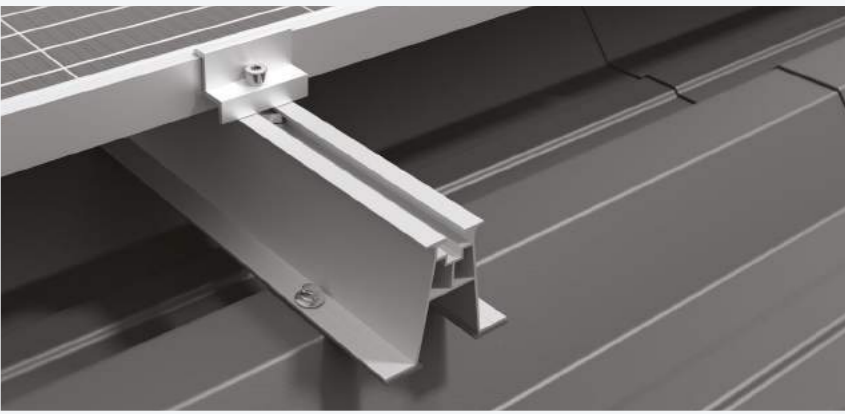
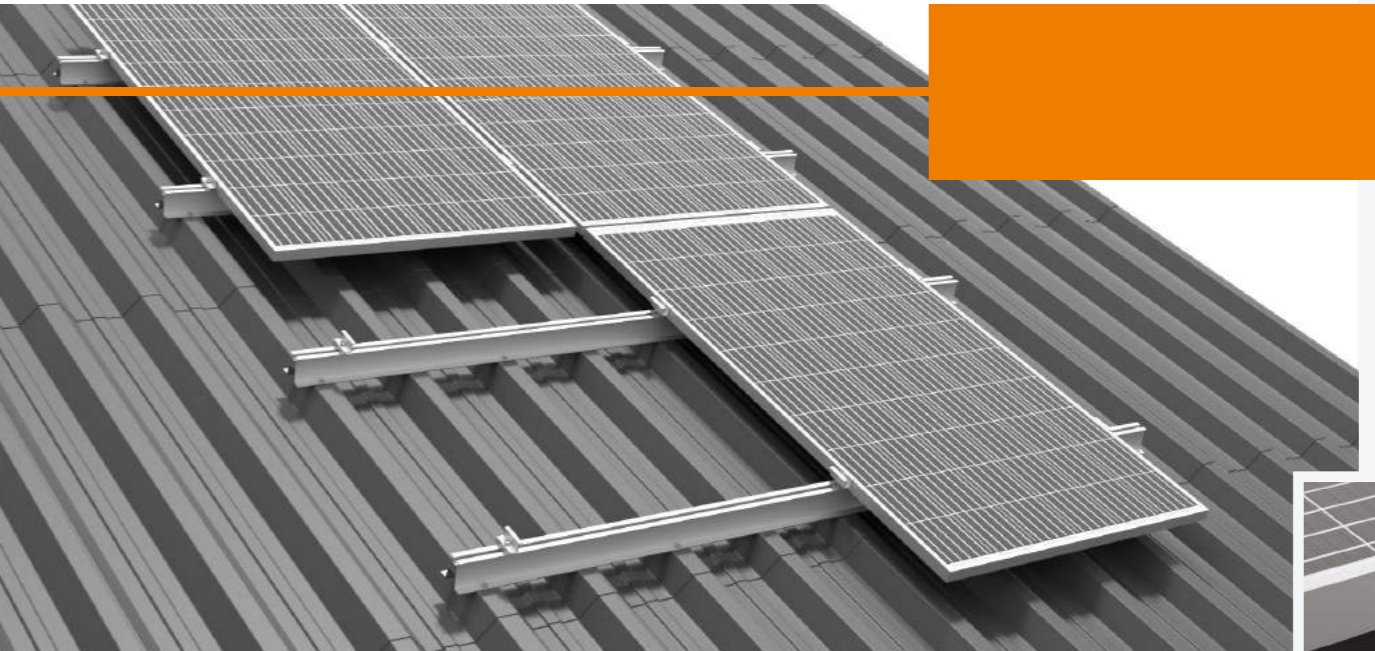



# Systems FOR PITCHED ROOF

## COVERED WITH SHEET METAL JOINED WITH A SEAM

▶ The installation does not interfere with the roof decking.

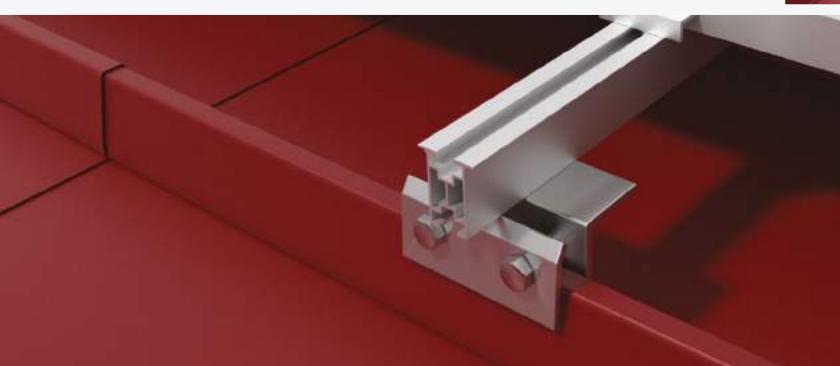
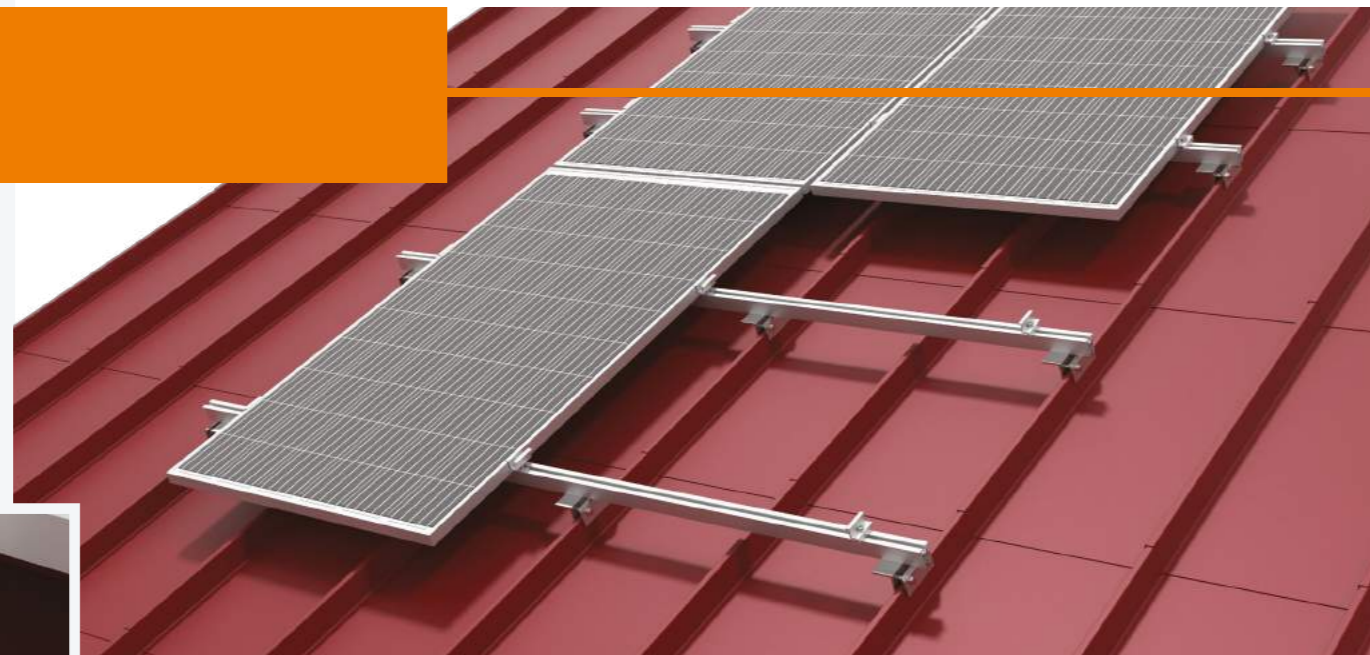

## COVERED WITH ROOF SHINGLE / SLATE TILES

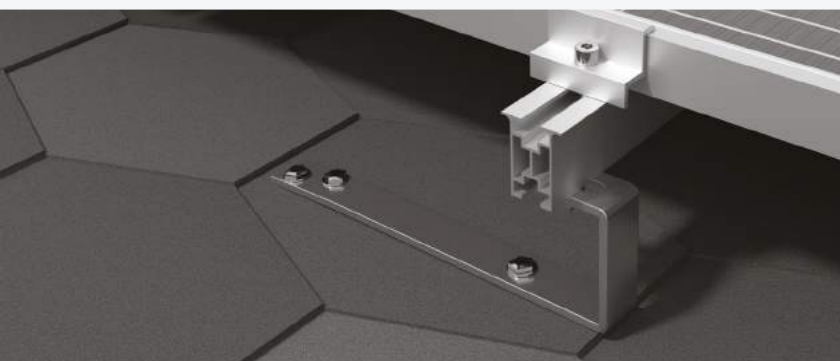
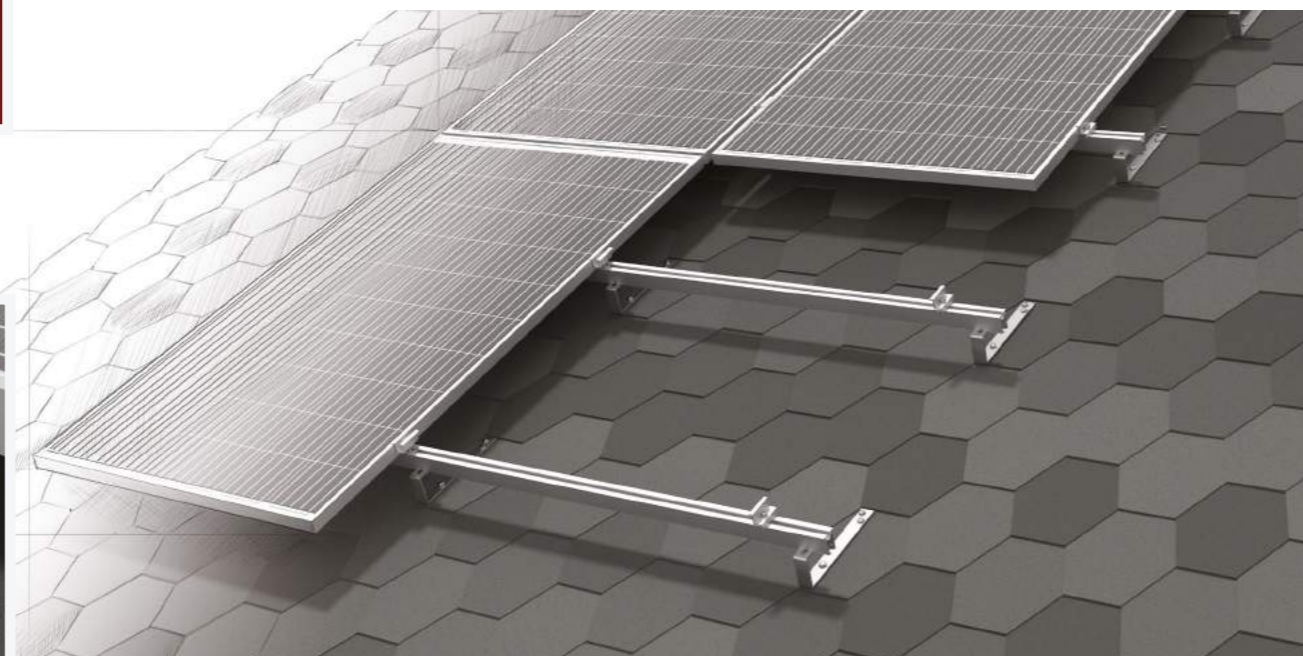

# Systems FOR PITCHED ROOF



## COVERED WITH CERAMIC TILES



## COVERED WITH FLAT TILES







# Systems for a roof COVERED WITH SANDWICH PANELS



## Customised design

Systems for a roof covered with sandwich panels are fixed to the roof substructure, for example, using roofing screws. The steel profiles fixed to purlins are used - this solution prevents transfer of the load onto the sandwich panel and its permanent damage. Each design is analysed individually, so you can be sure that together we will find the best solution.



a 10-year guarantee for the systems



vertical or horizontal layout of the modules



structures adopted to glass-glass modules



# Systems for a roof COVERED WITH SANDWICH PANELS

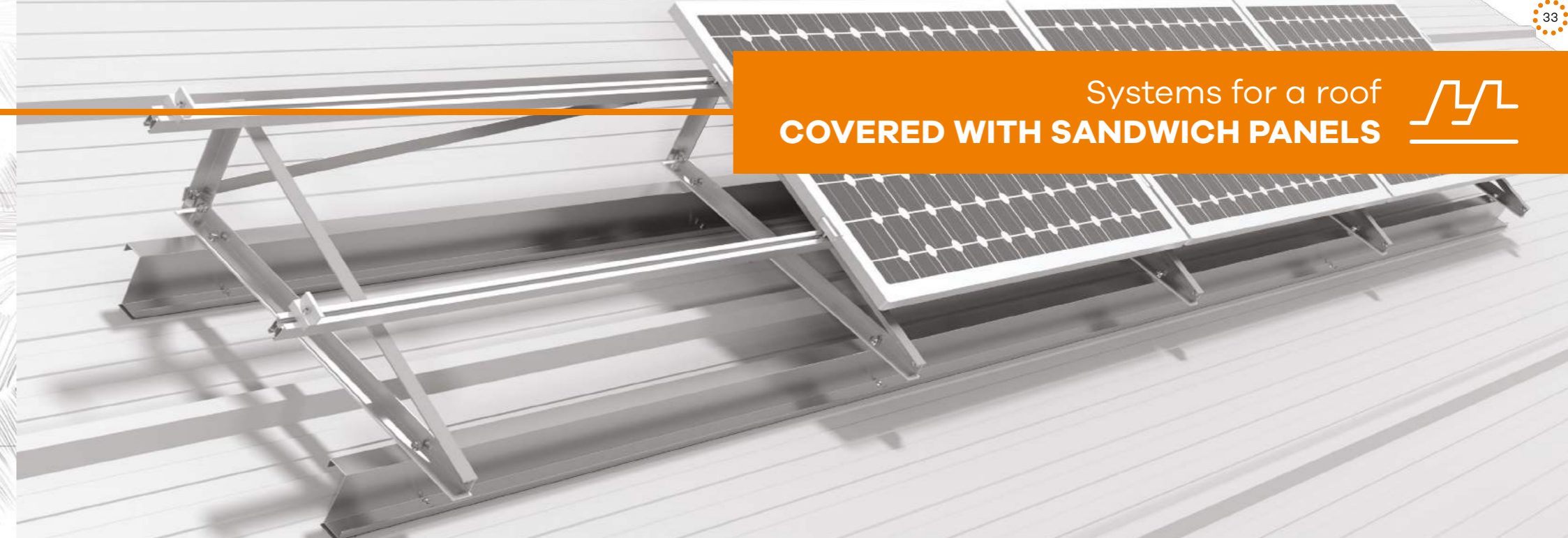

## EKIERKA ECO - FLAT ROOF SYSTEM SOUTH

TECHNICAL SPECIFICATION	
Material systemu	Aluminium and Magnelis® steel sheet
Roof type	Flat/sandwich panel
Module orientation	Vertical / horizontal
Fixing system	Triangles 10° – 35°
Roof surface area for 1 kW	6.8 m <sup>2</sup> (for the 1650x992 module)
Roof load (a module of 20 kg 250 W was assumed)	135.2 kg/1 kW 19.9 kg/m <sup>2</sup>

Note: The calculations did not take into account the snow load and wind pressure/suction

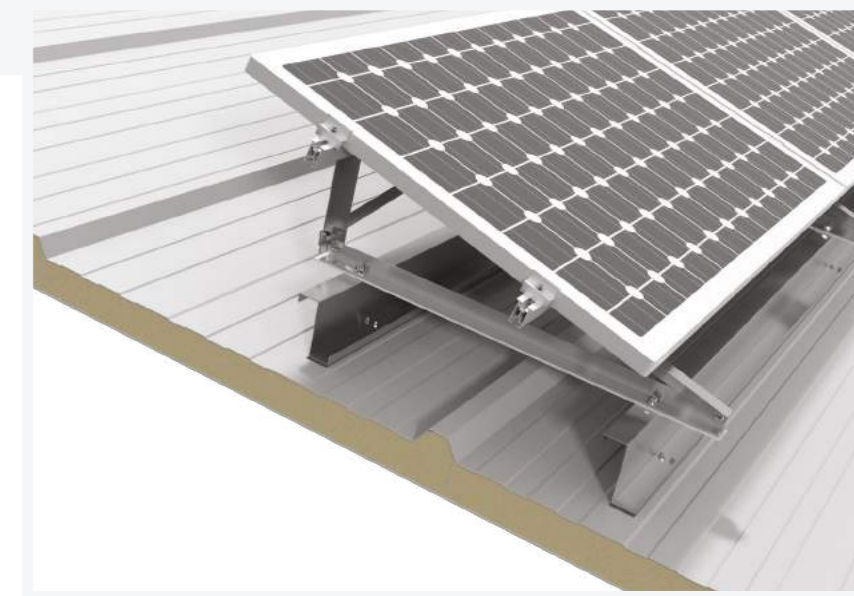



Systems for a roof  
**COVERED WITH SANDWICH PANELS**

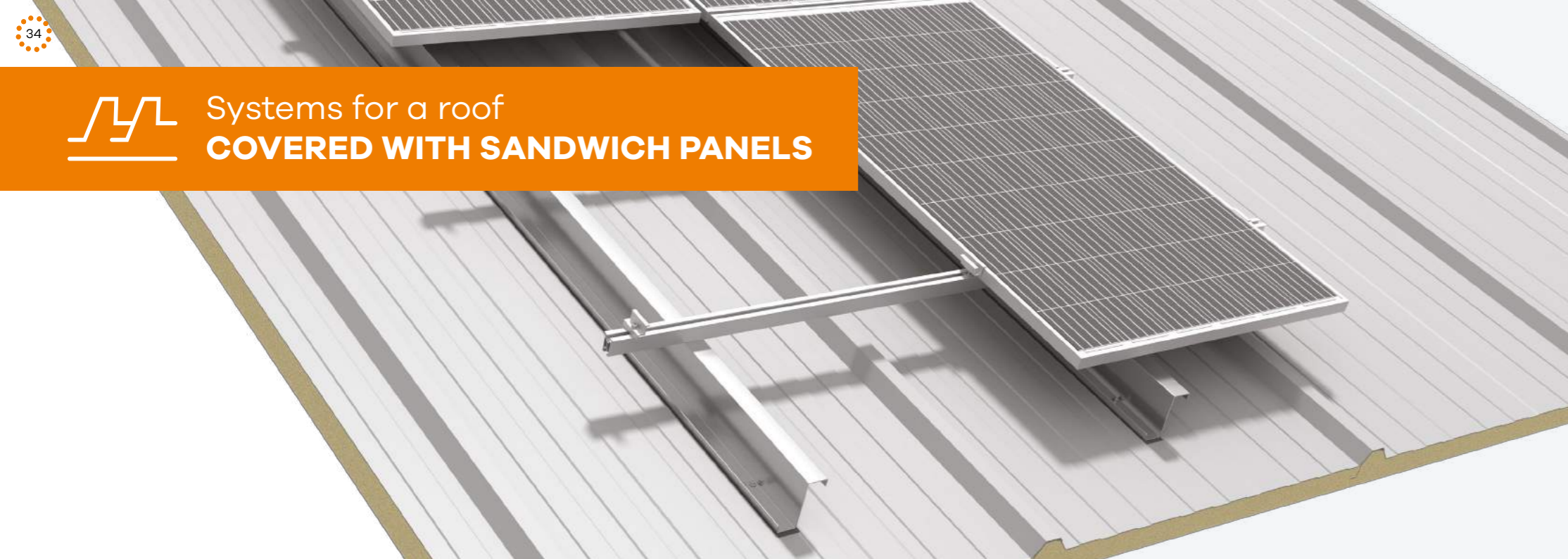

**PITCHED ROOF SYSTEM**

**TECHNICAL SPECIFICATION**

System material	Aluminium and Magnelis® steel sheet
Roof type	Pitched/sandwich panel
Module orientation	Vertical
Fixing system	Along the longer side, cross installation
Roof surface area for 1 kW	6.65 m <sup>2</sup> (for the 1650x992 module)
Roof load (a module of 20 kg 250 W was assumed)	103.7 kg/1 kW 15.6 kg/m <sup>2</sup>

Note: The calculations did not take into account the snow load and wind pressure/suction

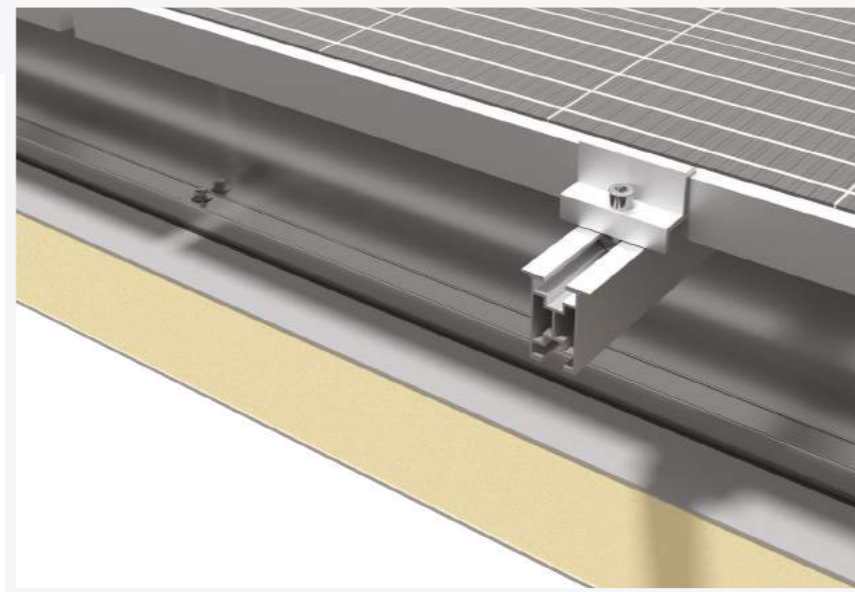

**AUTOBOX SYSTEM**



▶ **What the AUTOBOX systems are?**

The **AUTOBOX systems** are ground structures intended to be used at parking spaces. This solution combines a functionality of a shed with a photovoltaic system which can be adapted to be used as a charging station for electric cars powered by energy obtained from a photovoltaic system.

▶ **Properties and structures**

AUTOBOX systems are available as a **single** (two parking spaces) or a **multi-segmented** option, with a roof incline up to 10°. The load bearing structure, supported at two points, can be covered with trapezoidal sheet metal or be formed solely of purlins of cold-bended profiles. The shed structure is made of **hot-dip galvanised steel**, and the components of the support structure, to which modules and connectors are fixed, are **aluminium**.



**a 10-year guarantee**  
for the systems



a structure can be covered with  
**trapezoidal sheet metal**



**vertical or horizontal layout**  
of the modules



**a single- or a multi-segmented**  
shed



### ▶ What the BIPV façade systems are?

The **Building Integrated Photovoltaics (BIPV)** façade systems are an ideal solutions when there is no space for a ground system, and the roof structure makes installation of PV modules difficult or impossible.

### ▶ Modern technology

There is a gap (20 mm) between the insulating material and the external cladding (made of modules), ensuring **air circulation**, and this **improves thermal insulation** of a building, and allows to **remove moisture**.

### ▶ Effectiveness and aesthetics

The systems designed for fixing to a façade are not only **exceptionally effective**, but also **aesthetic - they emphasise the modern character of the building**. The façade systems can be used in office, hospital or educational buildings.

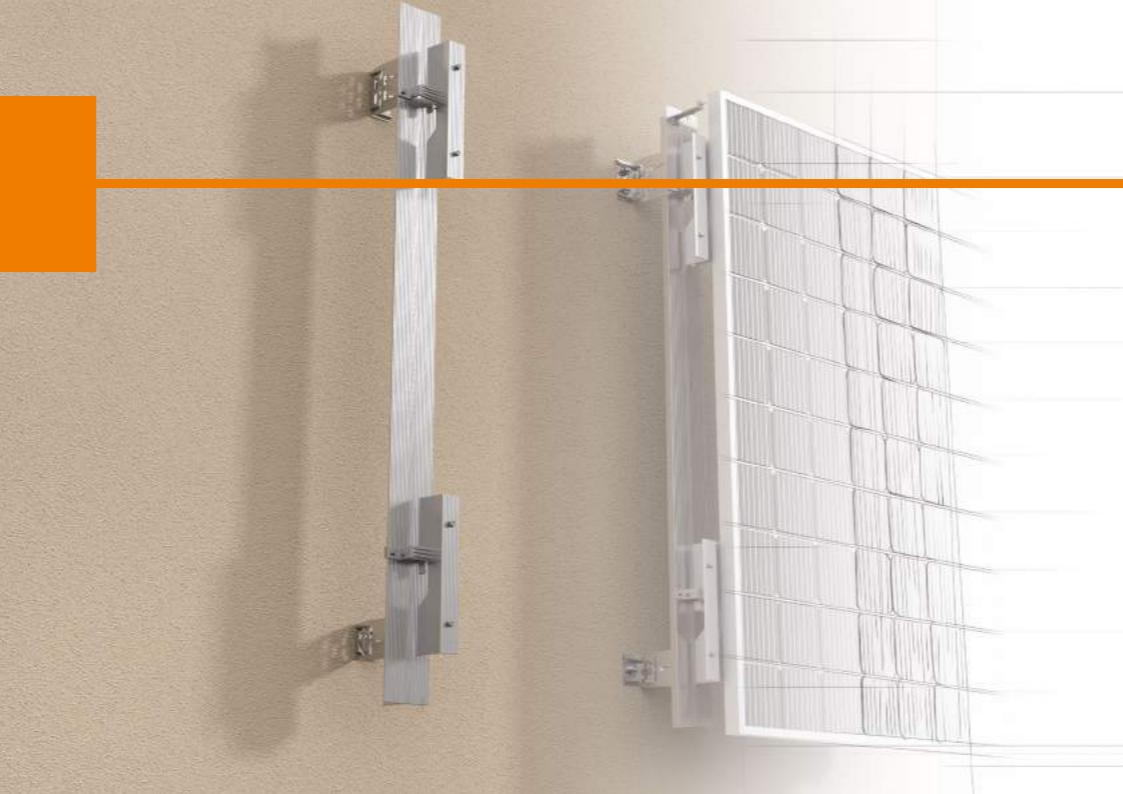

a **10-year guarantee** for the systems



**improved air circulation**



**any layout of the modules**



structures adopted to **glass-glass modules**



### ▶ Customised systems

We manufacture many non-standard systems, not available anywhere else in the market. We develop each system individually, with a support of well-qualified engineers, so each design is optimised in terms of a layout of modules.





Completed  
**FREESTANDING PROJECTS**



Completed  
**FREESTANDING PROJECTS**





# Completed ROOF PROJECTS

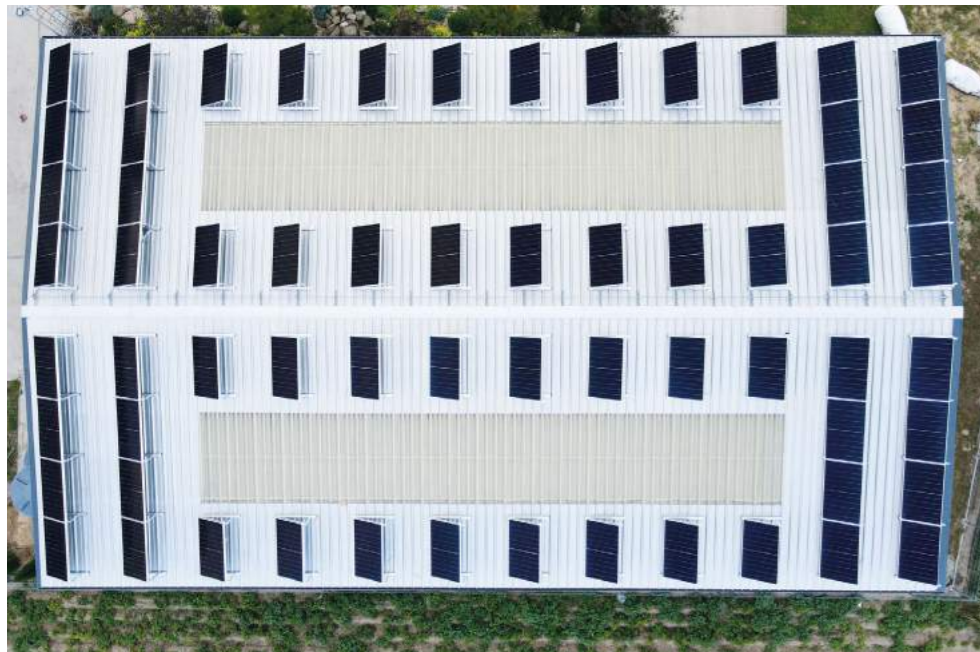

# Completed ROOF PROJECTS





# Completed AUTOBOX AND FAÇADES PROJECTS





**Energy5 Sp. z o.o.**  
**registered office**  
Ziejkowa 5  
09-500 Gostynin  
POLAND

Branch in Brześć Kujawski  
Kolejowa 15-17  
87-880 Brześć Kujawski  
POLAND

VAT No.: 971-072-32-96

e-mail: [biuro@energy5.pl](mailto:biuro@energy5.pl)  
tel: +48 (24) 235 40 79

**Jacek Lipowski**  
Export Sales Director

+48 694 923 357  
[jlipowski@energy5.pl](mailto:jlipowski@energy5.pl)

**Tomasz Aleksander**  
Deputy Export Sales Director

+48 882 493 692  
[taleksander@energy5.pl](mailto:taleksander@energy5.pl)

**Jan Brejcha**  
Country Manager

+48 604 277 420  
[jbrejcha@energy5.pl](mailto:jbrejcha@energy5.pl)

