

Driven in system with two supports, vertical layout of modules

W1 view 7067-6932

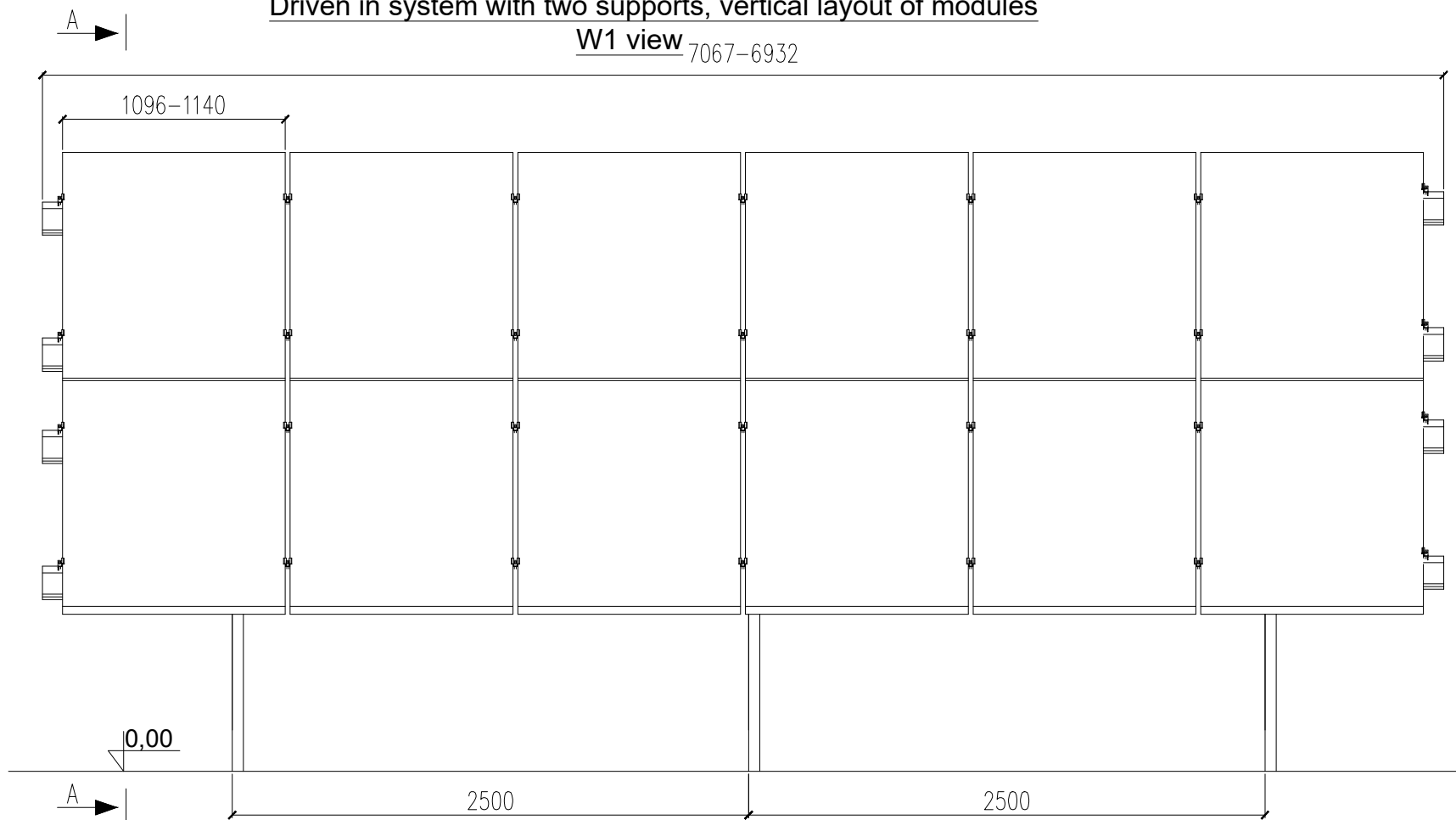

A-A

W1 view

Purlin  
Z-PROFILE 15/50/60/50/15/1,5  
ZM coating

Rafter  
C-PROFILE 15/50/100/50/15/1,5  
ZM coating

Rear profile  
C-PROFILE 15/100/50/15/2,5  
ZM coating

Bracket  
L-PROFILE 50x35x2,5  
ZM coating

Front profile  
C-PROFIL 15/100/50/15/2,5  
ZM coating

holes for grounding 4xØ10-12

0,00

~1500 dia 30°  
~1740 dia 25°

2170

~600

25°-30°

~4582

2120-2280

2120-2280

~1500

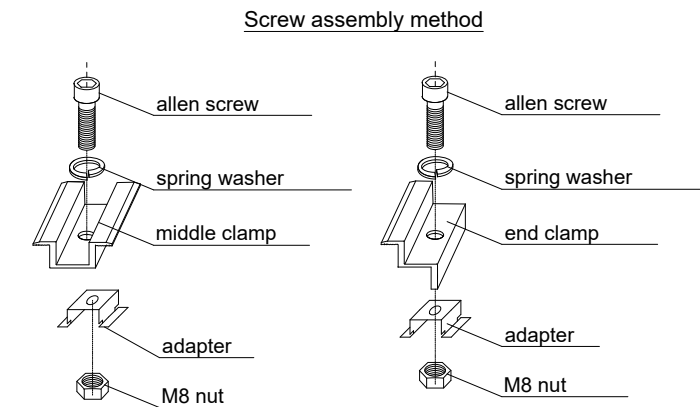
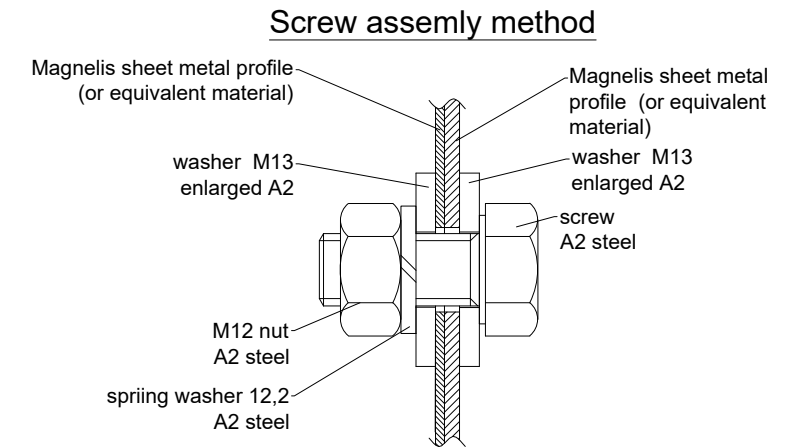

All drawings and/or studies are the property of the design team of Energy5 Sp. z o.o. Sharing, reproduction, any activities related to changes and dissemination of designs or author's ideas is prohibited without the written consent of Energy5 Sp. z o.o.

NOTE:  
Individual free-standing systems depend on the snow and wind load zone.  
- Wind - load value according to PN-EN 1991-1-4  
- Snow - load value according to PN-EN 1991-1-3

The offered products in the form of cold-formed steel sections are made in accordance with the PN-EN 10162 standard

The presented offer sheet is for illustrative purposes only. The assembly of the presented table should be carried out on the basis of the assembly instructions

Energy5 sp. z o.o. reserves the right to use a material equivalent to that of Magnelis coating. Equivalent means that Energy5 sp. z o.o. has its own tests of substitute / equivalent material in the corrosive range carried out by an accredited laboratory. The results of these tests confirm the parameters are no worse than in the case of the Magnelis coating.

Energy 5 Sp.z o.o.  
ul. Ziejkowa 5, 09-500 Gostynin  
www.energy5.pl  
tel: +48 (24) 362 08 48  
fax: +48 (24) 362 08 49



Drawing title:  
Driven in system with two supports, 25°-30°, vertical 2x6 layout

Scale:  
1:20

Drawing no.:  
WS2W\_25°-30°V\_2x6

Sheet:  
A3