

W1 VIEW - 4x4 system - scale 1:50

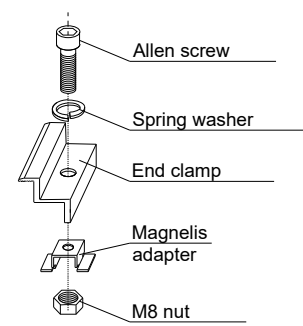

W1 view - 4x3 system - scale 1:50

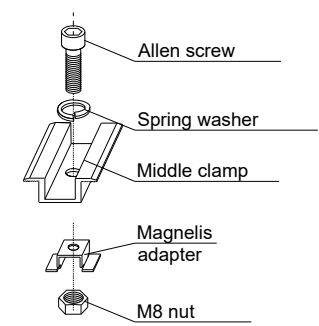
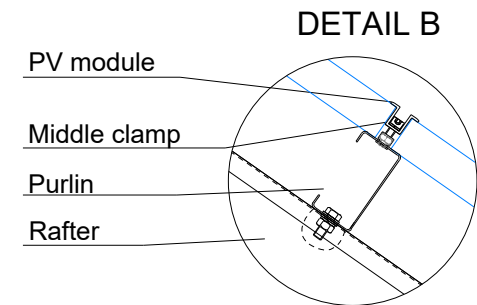
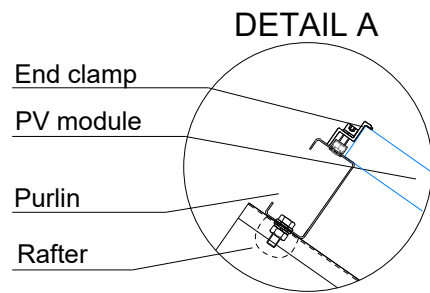
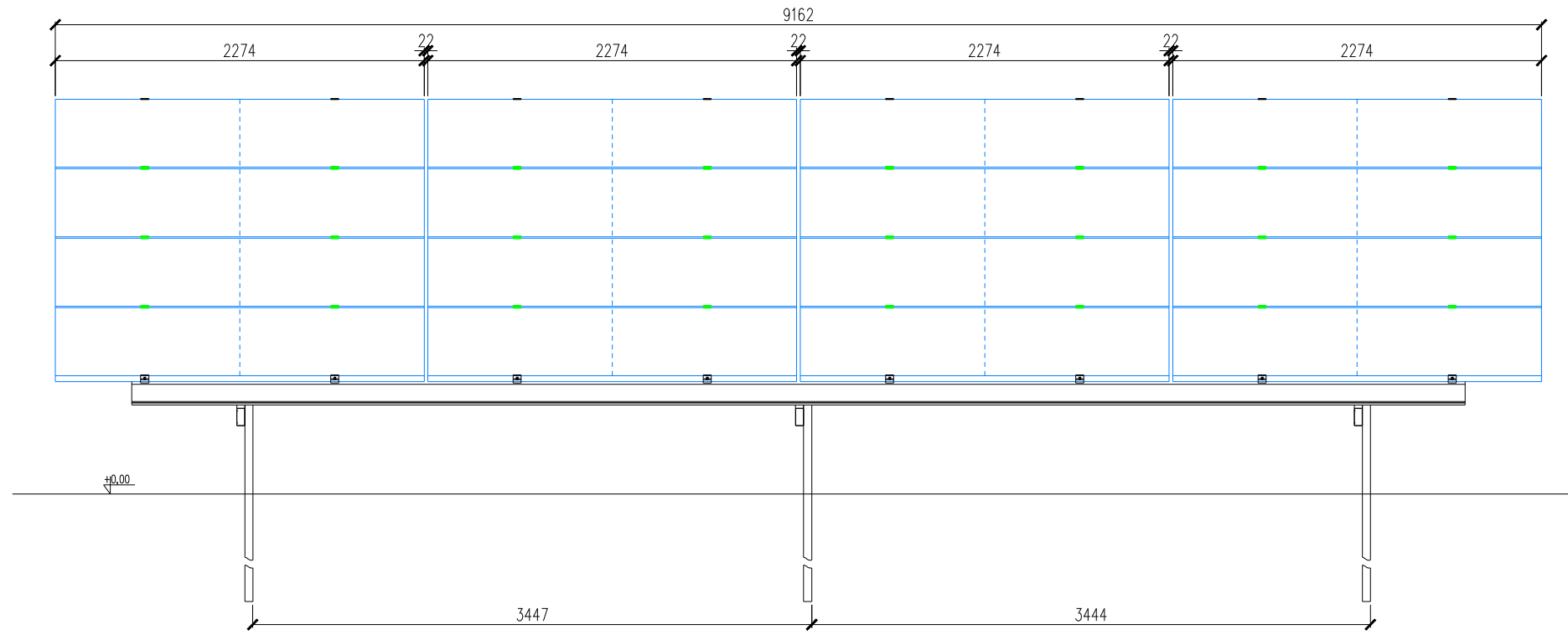
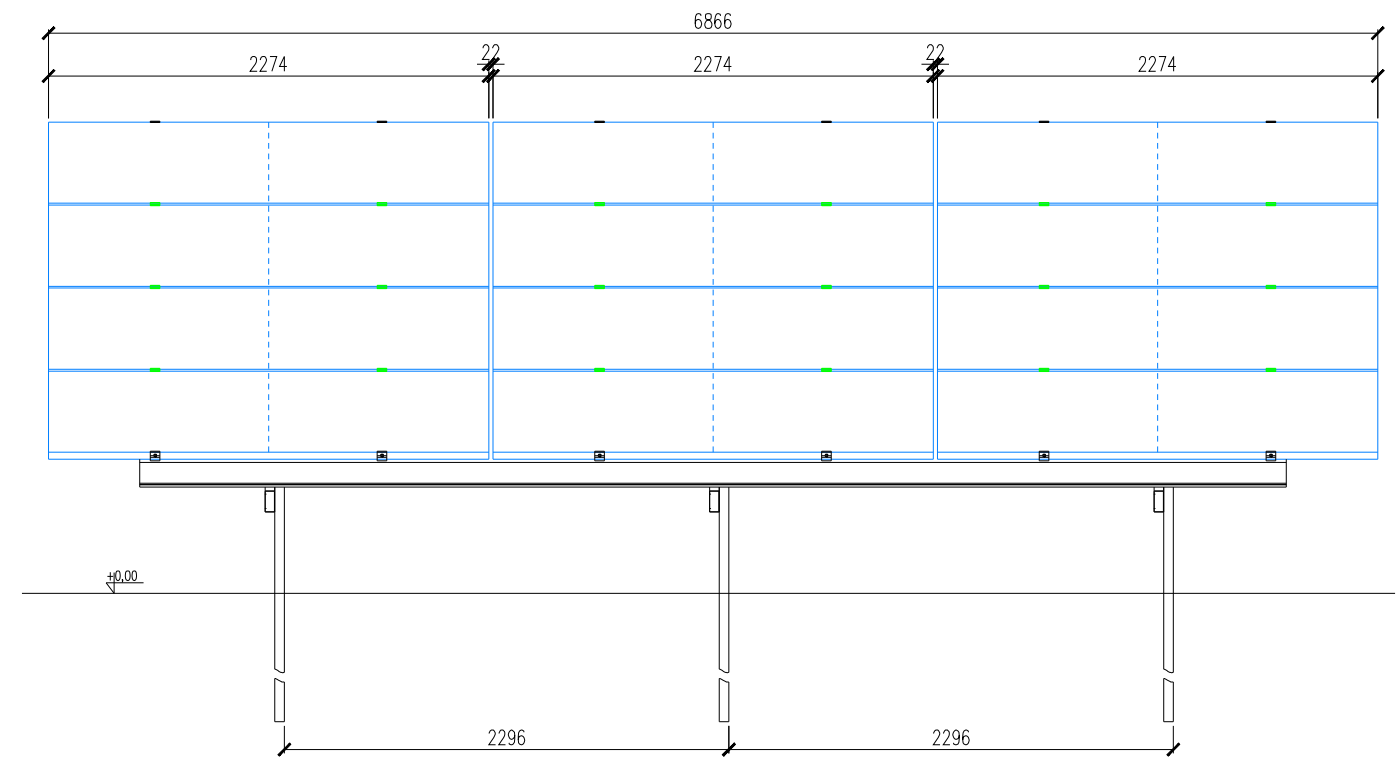

CROSS-SECTION A-A

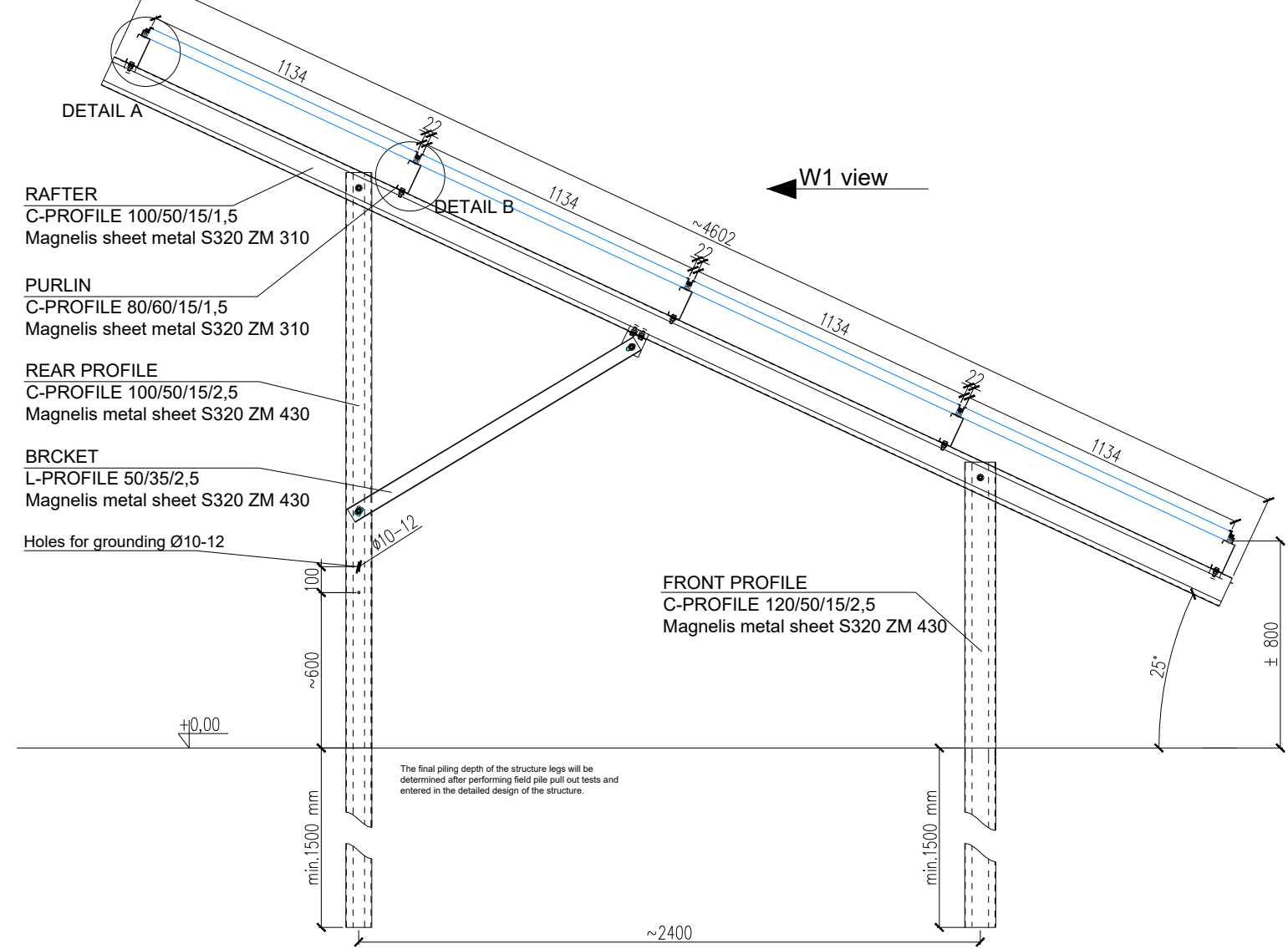

NOTE:
Individual freestanding systems depend on the snow and wind load zone.

- Wind - load value according to PN-EN 1991-1-4
- Snow - load value according to PN-EN 1991-1-3

The presented offer card is for illustrative purposes only.

The assembly of the presented system should be performed based on the assembly instructions.

All drawings and/or studies are the property of the design team of Energy5 Sp. z o.o.. Sharing, duplicating, any activities related to changes and distribution of designs, author's ideas is prohibited without the written consent of Energy5 Sp. z o.o.

<p>Energy 5 Sp. z o.o. ul. Ziejkowa 5, 09-500 Gostynin www.energy5.pl tel: +48 (24) 362 08 48 fax: +48 (24) 362 08 49</p>		
<p>Title: Bifacial system with two supports, 2xV layout, 25°</p>	<p>Scale: ----</p>	
<p>Drawing no.: Bifacial 2xV layout</p>	<p>Sheet: A3</p>	